

SEZIONE A-A
SCALA 3:20

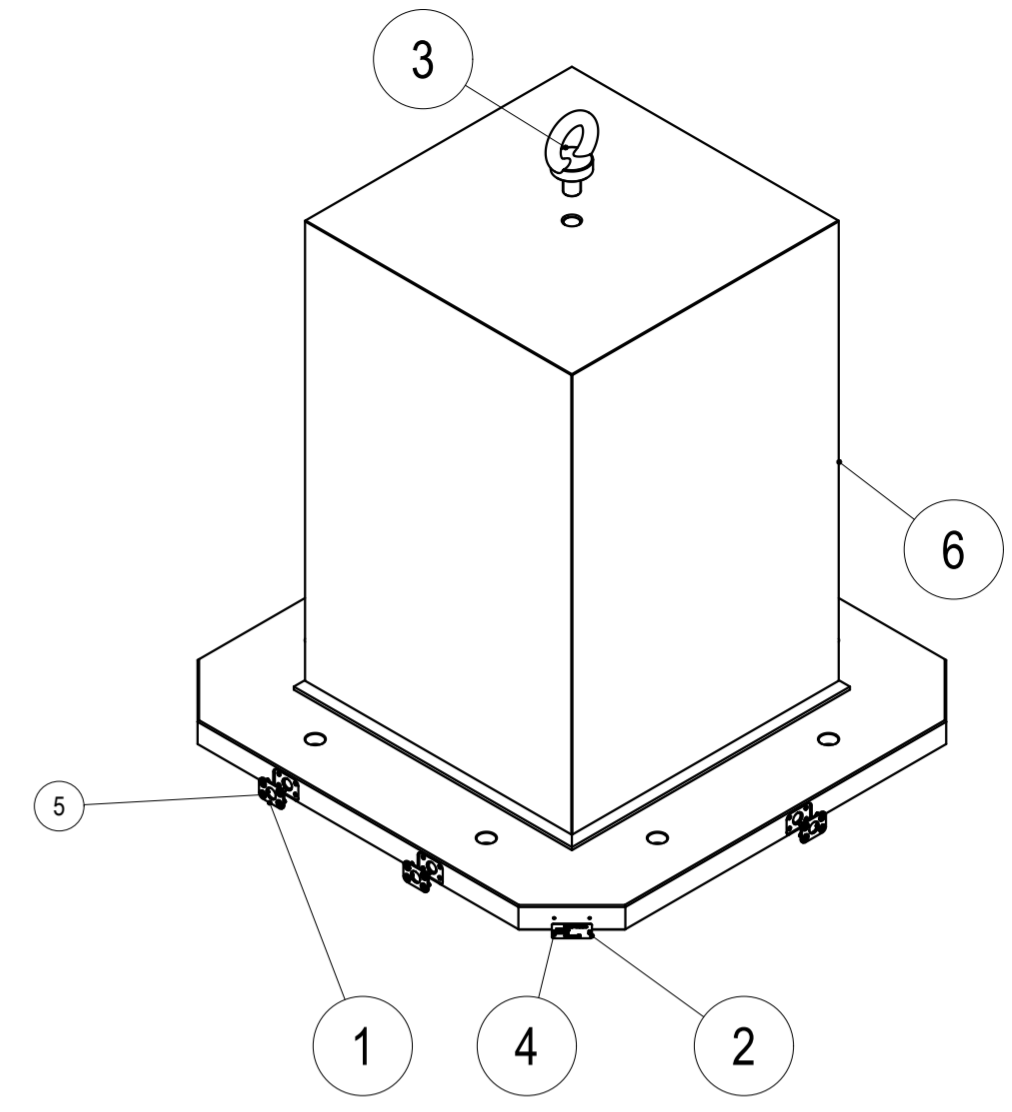

SCALA 1:10

POS.	CODICE - CODE	DESCRIZIONE - DESCRIPTION	Q.TY
1	4SH45322	Piastrina riferimento laterale Lateral reference plate	3
2	4SH53231	Piastra identificativa Portapezzi Tombstone Serial Number plate	1
3	GOLFARE_M24	Golfare M24 Eyebolt M24	1
4	RIVETTO_2-3X5	Rivetto Ø2.3 x 5 Rivet Ø2.3 x 5	2
5	VTPSEL_M5X10	Vite testa piana svasata esagono incassato Countersunk socket head screw	12
6	W0000522724	Cubo portapezzi completamente finito Tombstone cube completely finished	1

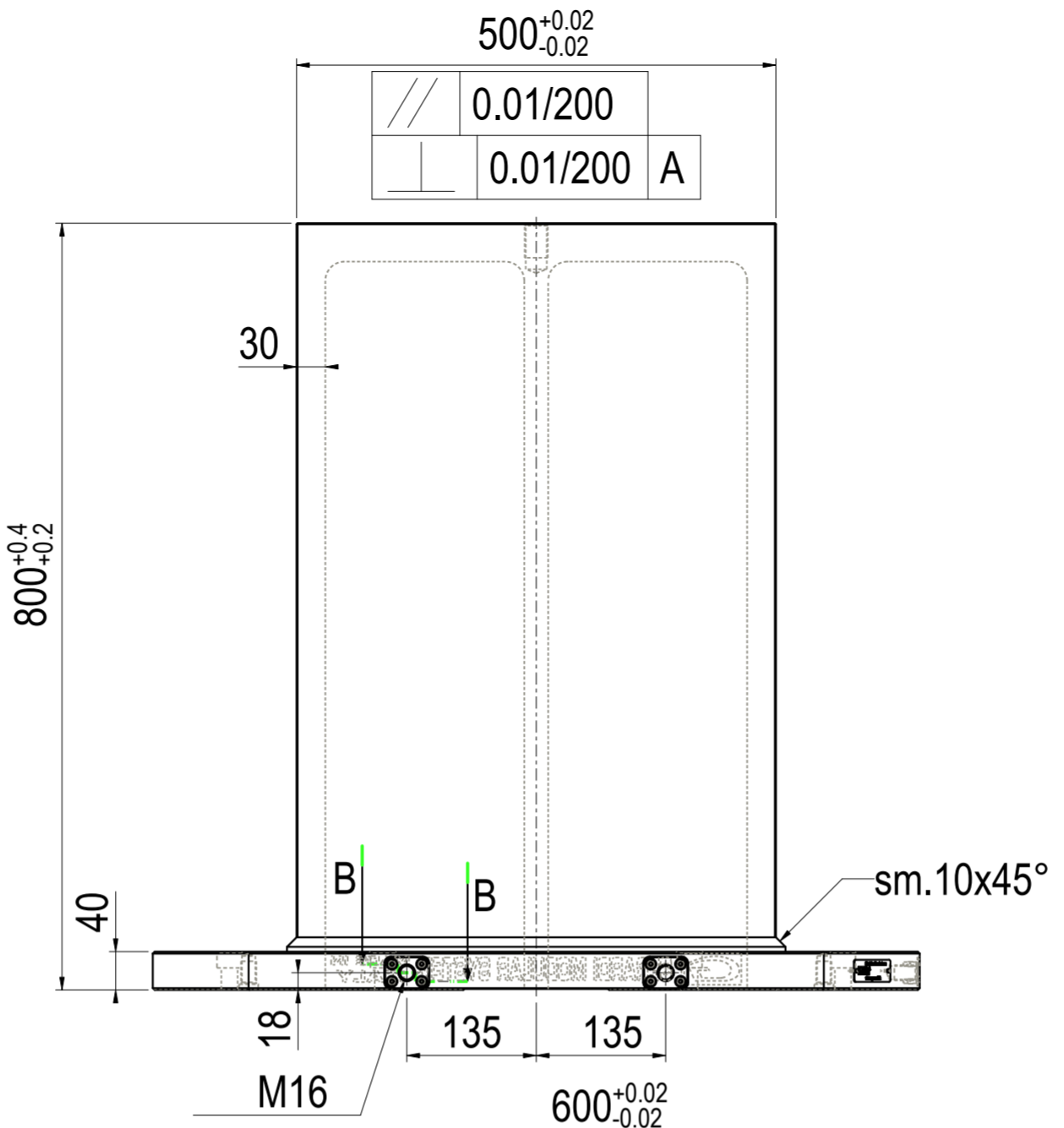
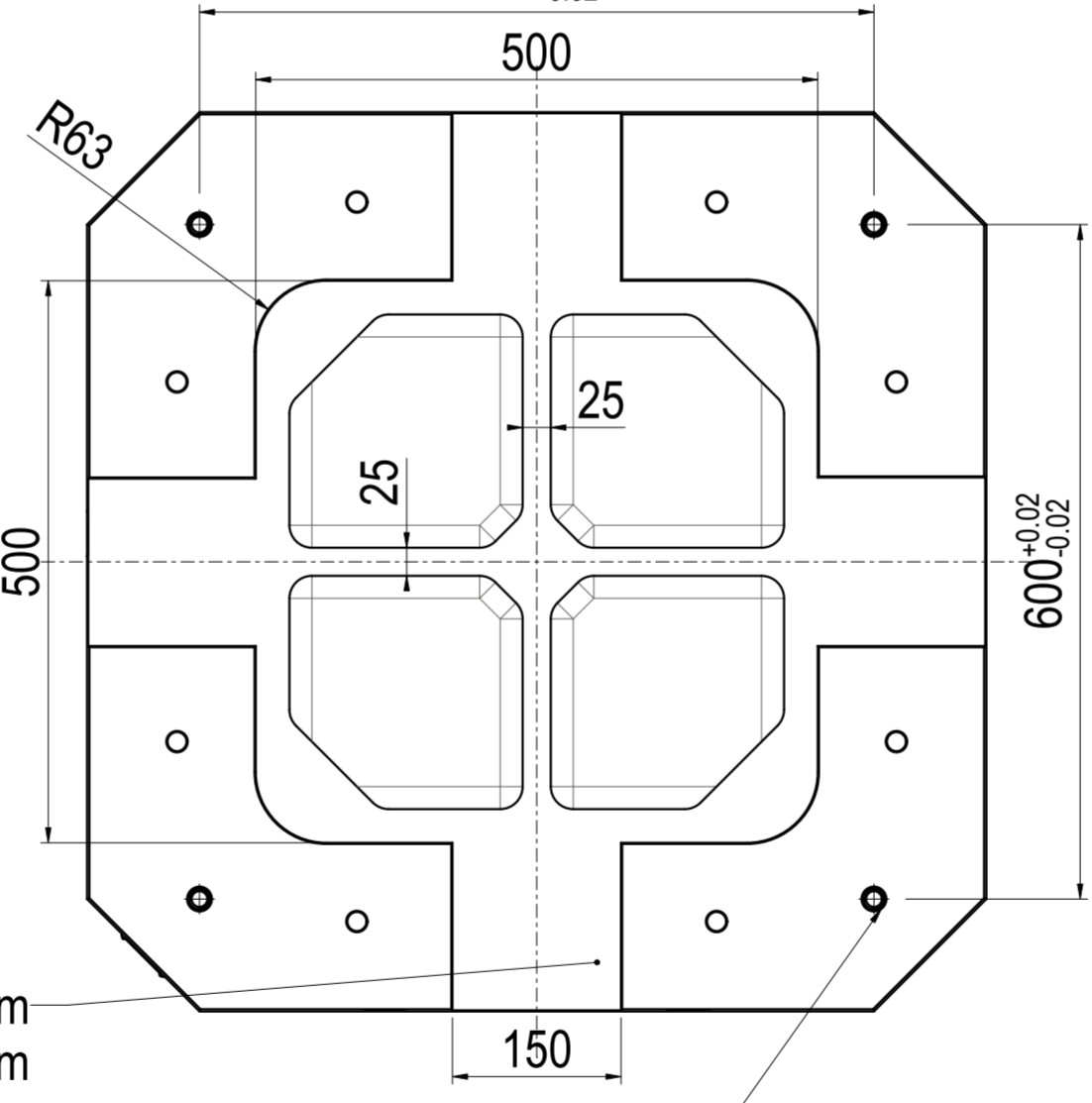
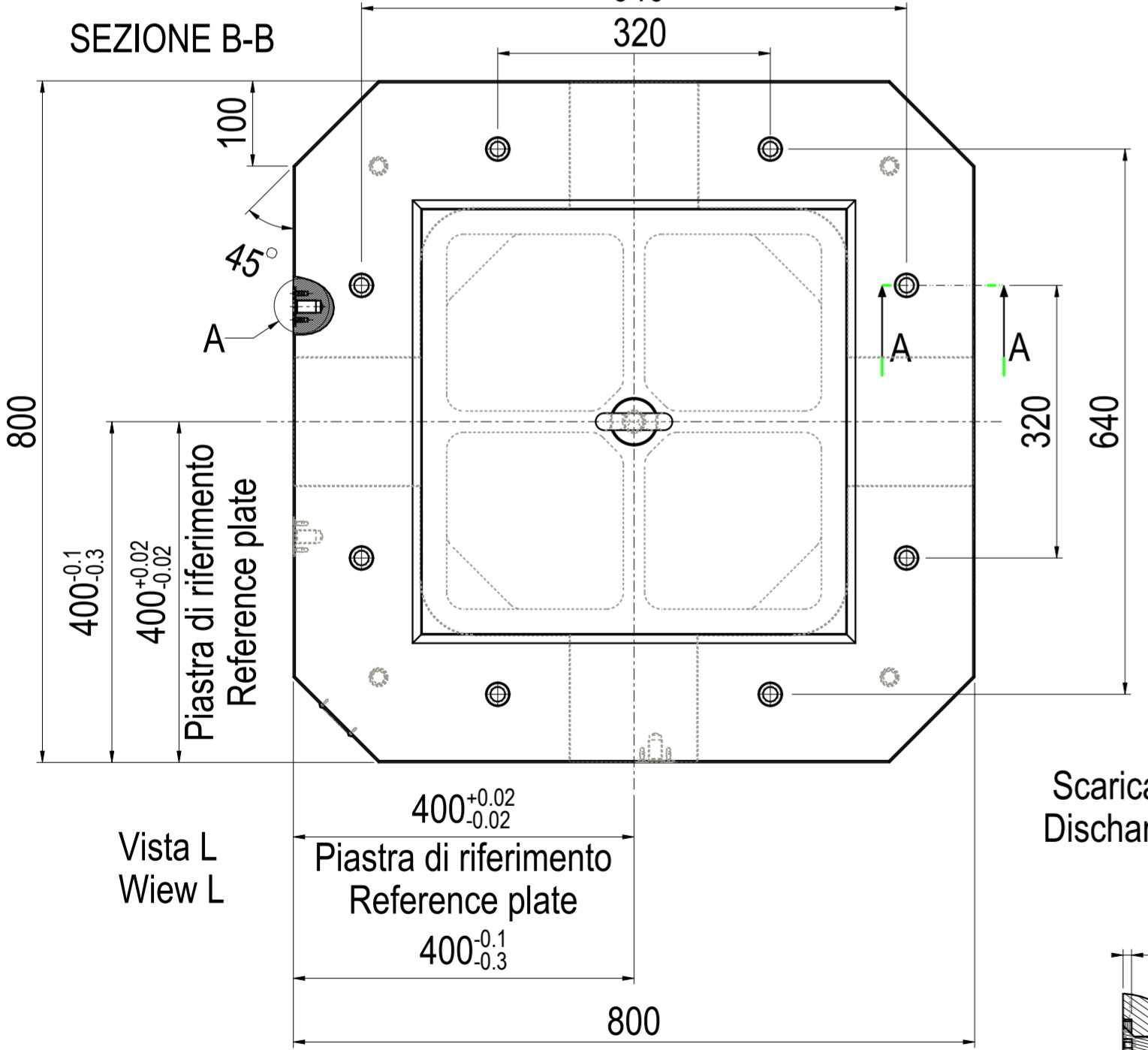

Scaricare 1mm
Discharge 1mm

Fori per Zero Point T.2 per nostra produzione
Zero Point holes T.2 for our production

ATTENZIONE:
- quote indicative da verificare in caso di offerta;
- possibile presenza di lavorazioni aggiuntive e/o forature extra;
- verificare la compatibilità della base col proprio pallet;
- possibilità di richiedere un preventivo per eventuali modifiche o personalizzazioni.

ATTENTION:
- indicative dimensions to be verified in the event of an offer;
- possible presence of additional machining and/or extra drilling;
- check the compatibility of the base with your pallet;
- possibility to request a quote for any change or customization.

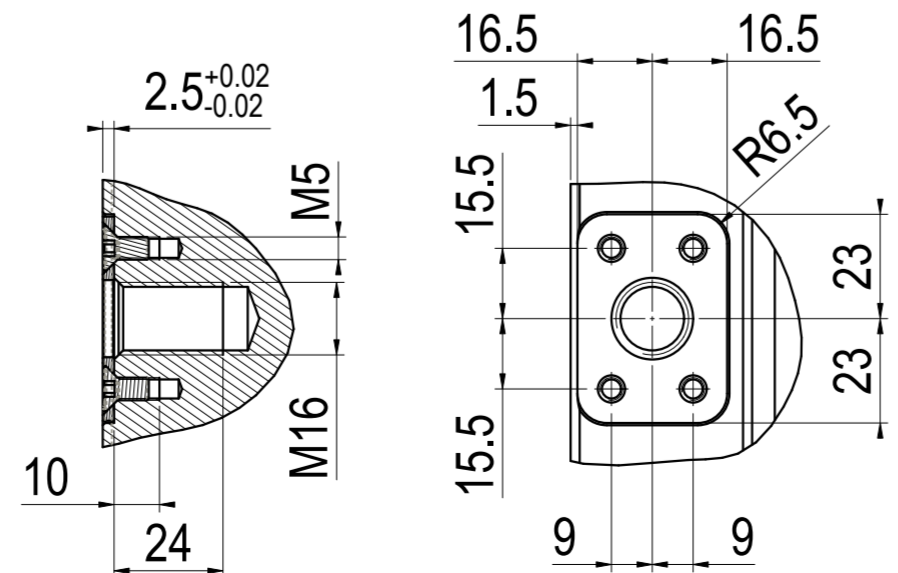
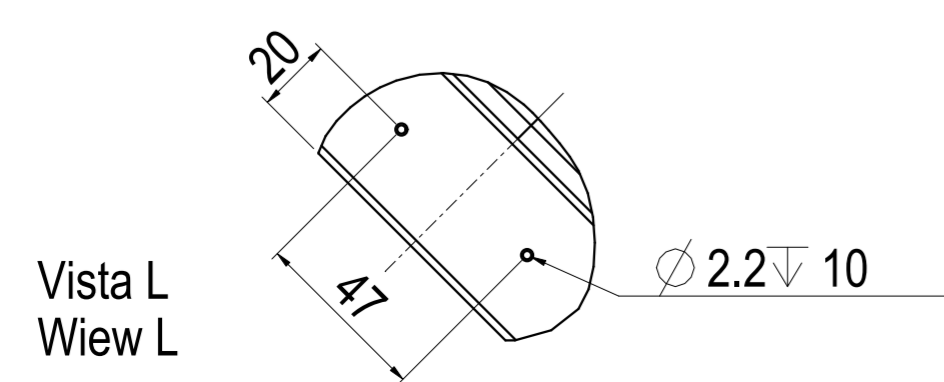

A(3:5)
Tip. 3 pos

Rev.	Description	Drawn by	Date	Approved by
A		A.Vigliotta		

	GERARDI S.p.A. Lonate Pozzolo (VA) Italy Tel. +39 0331303911 Fax +39 0331301534	Denominazione Denomination		Progettazione - UTILIZZO ESCLUSIVO UFFICIO TECNICO		
	Articolo Article	53C	Cubo quadrato completamente lavorato Square cube completely machined		Cliente Customer	-
Tipo Type	-	Disegnato da Drawn by	A. Vigliotta	Approvato da Approved by	Fabbisogno Q.ty needed	-
Peso Weight	Kg 634.30	Foglio Sheet	1 of 1	Codice commerciale Sales item code	853C00230	
Revisione Revision	A.1	Data Date	30/07/24	Disegno N° Drawing N°	W0000522719	

Questo disegno è di esclusiva proprietà della GERARDI S.p.A. la quale ne vieta la copia, la riproduzione e la cessione a terzi a norma di legge. This drawing is of GERARDI S.p.A. exclusive property. The copy and/or transfer to third parties is prohibited by law.