

Rev.	Description	Drawn by	Date	Approved by

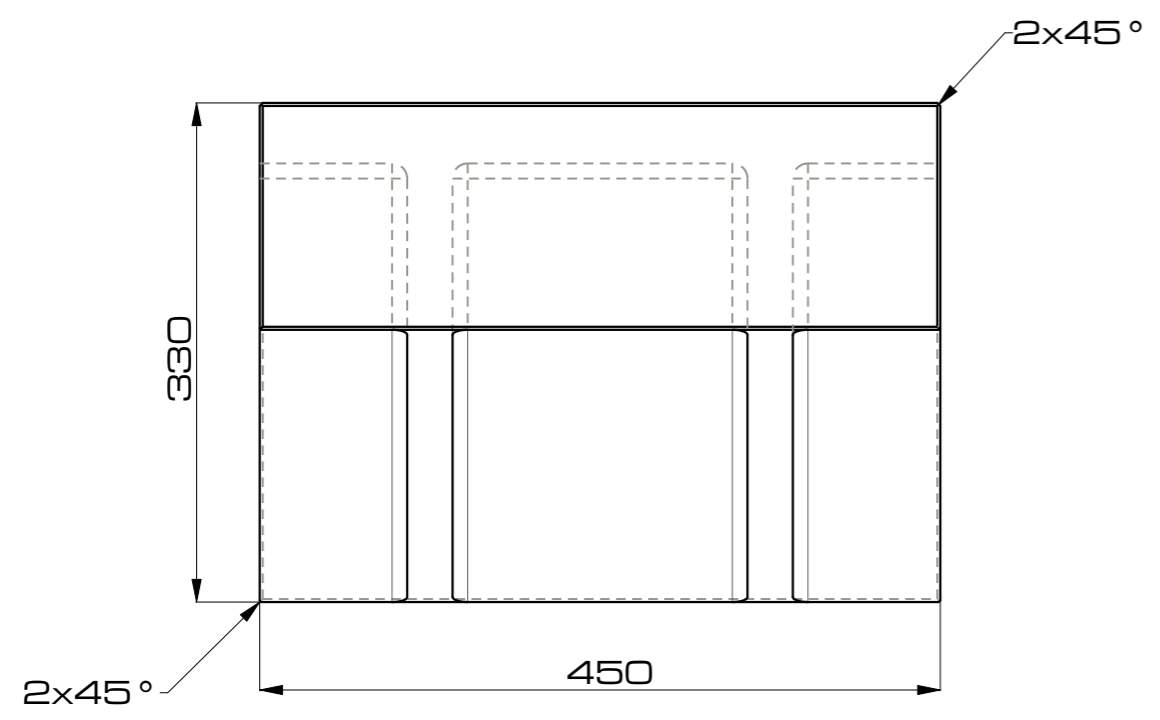
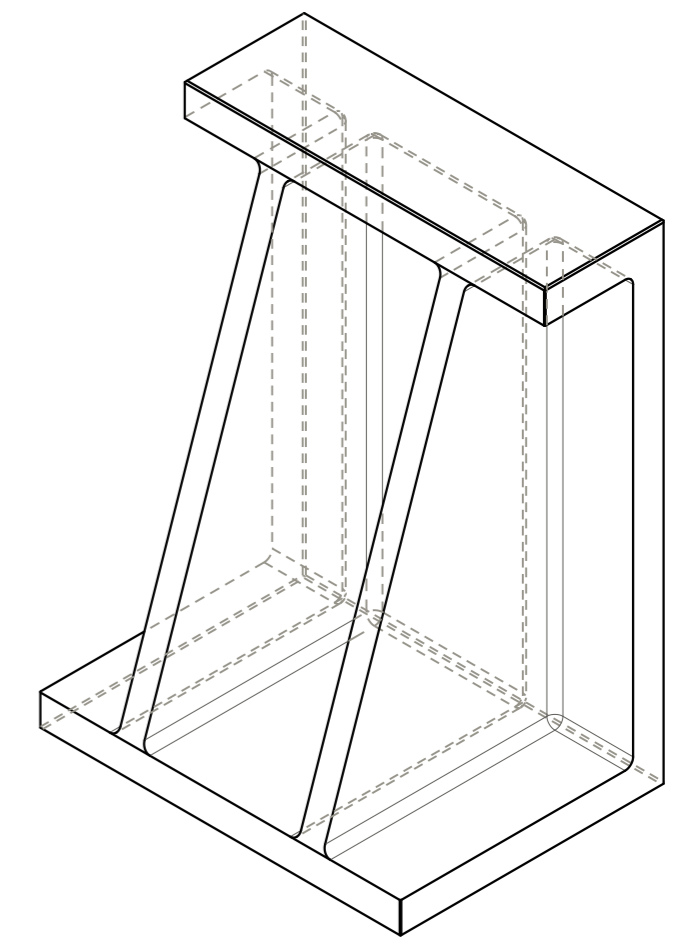
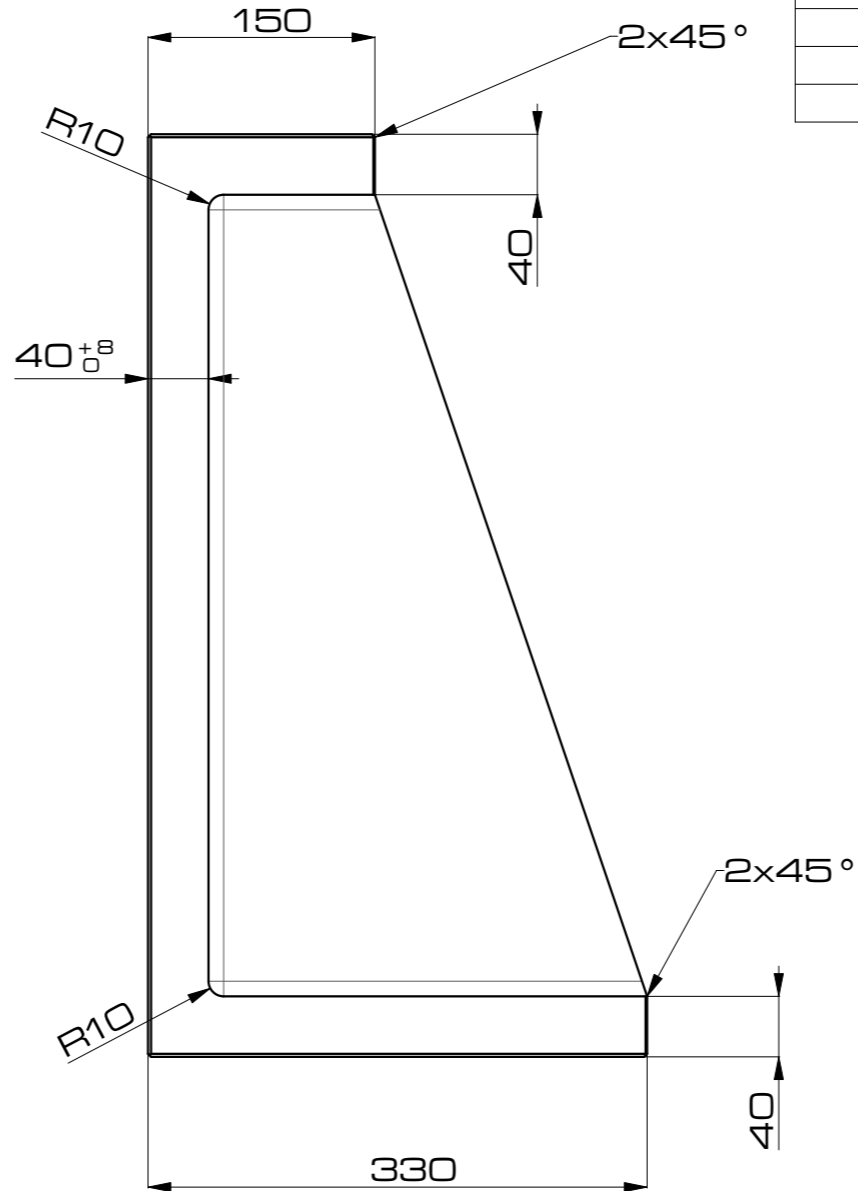
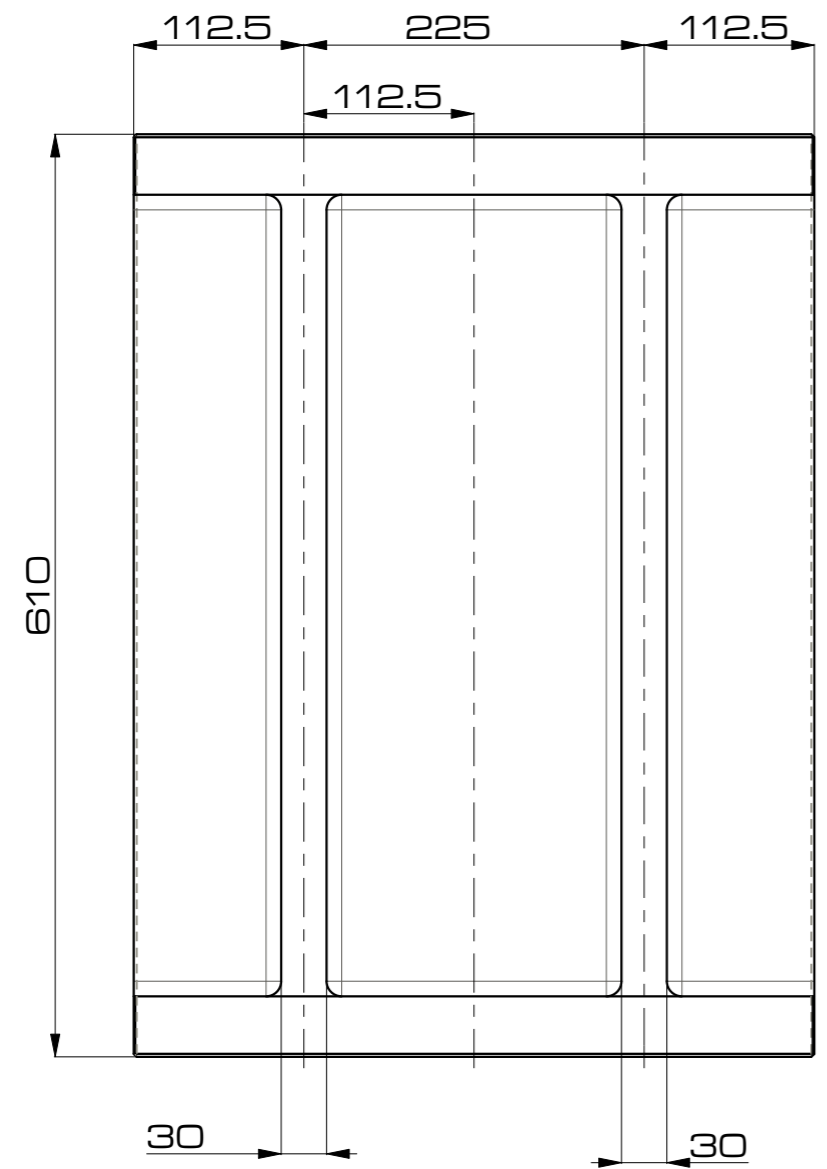

ATTENZIONE:

- quote indicative da verificare in caso di offerta;
- possibile presenza di lavorazioni aggiuntive e/o forature extra;
- verificare la compatibilità della base col proprio pallet;
- possibilità di richiedere un preventivo per eventuali modifiche o personalizzazioni.

ATTENTION:

- indicative dimensions to be verified in the event of an offer;
- possible presence of additional machining and/or extra drilling;
- check the compatibility of the base with your pallet;
- possibility to request a quote for any change or customization.

Family	-
Material	Øe *
Width	* *
Height	* *
Length	* *
Thickness	* *
Drawing	*

 GERARDI S.p.A. Lonate Pozzolo (VA) Italy Tel. +39 0331303911 Fax +39 0331301534		Denominazione Denomination		- UTILIZZO PER PREVENTIVI E CAMPIONATURE			
		Fusione squadra Angle casting			Cliente Customer	*	
Articolo Article	56A	Toll.non quotate Tol. not quoted	*	Fabbisogno Q.ty needed	*		
Material	G30	Tipo Type	*	Disegnato da Drawn by	M. Ottoboni		
Tratt. termico Heat treatment	Ricottura di distensione / Stress relieving	Peso Weight	Kg 179.78	Foglio Sheet	1 of 1	Approvato da Approved by	
Durezza Hardness	*	Revisione Revision	A.4	Codice commerciale Sales item code	*		
Tratt. superficiale Surface treatm.	-	Data Date	14-12-19	Disegno N° Drawing N°	856A00050		

Questo disegno è di esclusiva proprietà della GERARDI S.p.A. la quale ne vieta la copia, la riproduzione e la cessione a terzi a norma di legge. This drawing is of GERARDI S.p.A. exclusive property. The copy and/or transfer to third parties is prohibited by law.